

PHILIPS

SERVICE DOCUMENTATIE

voor de ontvanger

BX 640 A



R15540

1954

Voor voeding uit wisselstroomnetten

Knoppen

Links : Toonregelaar
: Volumeregelaar

Rechts : Afstemming
: Ferroceptor

Druktoetsen

Van links naar rechts:
Netschakelaar
pick-up schakelaar

L.G. : 1154 - 2000 m(260 - 150 kHz)
M.G. : 186 - 578 m(1610 - 519 kHz)
K.G. : 24,4 - 51,7 m(12,3- 5,8 MHz)
F.M. : 3 - 3,43 m(100 - 87,5 MHz)

Buizen

B1 = ECC85
B2 = ECH81
B3 = EBF80
B4 = EF 85
B5 = EABC80
B6 = EL 84
B7 = EZ 80
B8 = EM 80
B9 = EL 84
B10 = EBC41
B11 = EZ 80

Middenfrequenties

F.M. : 10,7 MHz
A.M. : 452 kHz

Netspanningen

110 - 125 - 220 V

Verbruik

94 W

Luidsprekers

9754 (Z= 7Ω)
9766 M (Z= 5Ω)

Schaalverlichtingslampjes

L1 = 8024 N - 91
L2 = 8024 N - 91

Afmetingen

Breedte : 627 mm
Hoogte : 384 mm
Diepte : 226 mm

93 981 77.1.22

AFREGELLEN VAN HET A.M. GEDEELTE

Voor alle A.M. kringen geldt het volgende:

Volumeregelaar op maximum.

Toonregelaar op kwaliteit.

Een voltmeter via trimtransformator aansluiten op de bussen voor de extra luidspreker.

Indien niet anders is aangegeven worden alle signalen toegevoerd aan de antennebus via een kunstantenne.

Na het afregelen de kernen en trimmers aflakken

<u>M.F. BANDFILTERS</u> (kernen van S33, S32, S28, S29 uitdraaien)				
Golfbereik	Wijzer op trimpunt	Signaal	Afregelen	Aanwijzing
M.G.	1	452 kHz op g1B2 via 33000 pF	S33, S32, S28 S29, S32	max. output max. output
<u>M.F. SPER-ZUIGKRING</u> (kernen van S11 en S12 uitdraaien)				
MG [⌘]	2	452 kHz	S11, S12, S11	<u>min.</u> output
H.F. KRINGEN (Wijzer instellen op trimpunt 1)				
K.G. ^{⌘⌘}	2	6,38 MHz	S23, S5 } herh. C32, C9 }	max. output
	1	11,73 MHz		max. output
M.G. [⌘]	2	610 kHz	S25 } herh. C33 }	max. output
	1	1500 kHz		max. output
M.G.	2	610 kHz ^{⌘⌘}	S 6 } herh. C10 }	max. output
	1	1500 kHz		max. output
L.G. [⌘]	2	169,5 kHz ^{⌘⌘}	C70 } herh. S 7 }	max. output
	2	169,5 kHz		max. output
<u>L.G. SPIEGELFILTER</u> (S42 indraaien)				
L.G.	Apparaat afstemmen op 230 kHz	1134 kHz	S42	<u>min.</u> output

⌘ De punten 1 en 2 van strip A doorverbinden

⌘⌘ Deze doorverbinding weer opheffen.

Men moet er op letten dat de doorverbinding c.q. opheffing steeds geschiedt op de momenten aangegeven in de trimp tabel.

F.M. GEDEELTE

Afregelen met behulp van een F.M. oscillator

Voor het afregelen van alle F.M. kringen geldt:

F.M. bereik inschakelen.

Volumeregelaar op maximum, toonregelaar op kwaliteit.

Diodevoltmeter aansluiten over C56 (voltmeter niet aarden).

Een voltmeter via trimtransformator aansluiten op de bussen voor de extra luidspreker.

De spanning over C56 beperken op ca. 8 V.

<u>M.F. KRINGEN</u>					
Afstemcondensator op	Signaal	Oscillator aansluiten op	Dempen met 4700 Ω	Trimmen	Aanwijzing
max.	10,7 MHz zwaai 22,5 kHz m.fr. 500 Hz	g1B2 via 1500 pF	S30 S31 - -	S31 S30 S34 S36	max. D.V. max. D.V. max. D.V. max. output
max.	10,7 MHz zwaai 22,5 kHz m.fr. 500 Hz	g1B1 via 1500 pF	S27 S26 S21 -	S26 S27 S20 S21	max. output max. output max. output max. output
<u>H.F. KRINGEN</u>					
C11 bijna geheel uitdraaien.					
89,5 MHz	100 MHz zwaai 15 kHz m.fr. 500 Hz	FM Γ	- -	S13 C11	max. output max. output (1e piek)
87,5 MHz	87,5 MHz zwaai 15 kHz m.fr. 500 Hz	FM Γ	-	S13 S14-15	max. output
100 MHz	100 MHz zwaai 15 kHz m. fr. 500 Hz	FM Γ	-	C11 C12	max. output

Afregelen met behulp van een A.M. service oscillator

Voor het afregelen van alle F.M. kringen geldt:

Volume regelaar op maximum, toonregelaar op kwaliteit.

Diodevoltmeter aansluiten over C56, voltmeter niet aarden.

De spanning over C56 beperken op ca. 8 V.

Alle signalen zijn ongemoduleerd.

<u>M.F. KRINGEN</u>					
Afstemcondensator op	Signaal toevoeren van	Oscillator aansluiten op	Dempen met 4700 Ω	Trimmen	Aanwijzing
max.	10,7 MHz	g1B3 via 1500 pF	S30 S31 -	S31 S30 S34	max. D.V. max. D.V. max. D.V.
max. *	10,7 MHz	g1B3 via 1500 pF	-	S36	<u>min.</u> D.V.
max. **	10,7 MHz	g1B2 via 1500 pF	S27 S26	S26 S27	max. D.V. max. D.V.
	10,7 MHz	g1B1 via 1500 pF	S21 -	S20 S21	max. D.V. max. D.V.
<u>H.F. KRINGEN</u>					
C11 bijna geheel uitdraaien.					
88,5 MHz	100 MHz	FM \uparrow \downarrow	-	S13	max. D.V.
100 MHz	100 MHz	FM \uparrow \downarrow	-	C11	max. D.V. (te piek)
87,5 MHz	87,5 MHz	FM \uparrow \downarrow	-	S13-S14-15	max. D.V.
100 MHz	100 MHz	FM \uparrow \downarrow	-	C11, C12	max. D.V.

* Sluit twee in serie geschakelde weerstanden (220 k Ω 1%) aan over C56. Sluit de diodevoltmeter aan tussen het knooppunt van deze weerstanden en het knooppunt R22-C52.

** Verwijder de weerstanden en sluit de diodevoltmeter weer aan over C56.

LIJST VAN ONDERDELEN

	Omschrijving	Codenummer
	Schaal (N)	A3 743 11.2
	Kast	A3 739 92.0
	Bladveer voor achterwandbevestiging	A3 648 56.2
	Tulle voor chassisbevestiging	A3 642 15.0
	Knop (groot) M.C.	A3 751 61.0
	Bladveer (grote knop)	A3 650 18.0
	Knop (klein) M.C.	A3 751 59.0
	Bladveer (kleine knop)	A3 522 08.2
	Druktoets	A3 417 61.0
	Noval buishouder	B1 506 59.0
	Veerclip (dubbele spoelbus)	A3 652 58.3
	Veerclip (enkele spoelbus)	A3 652 75.1
	Variabele condensator	49 001 92.0
	Stekerbuisplaat (p.u.)	A3 382 13.0
	Spanningscaroussel	A3 228 84.0
	Trekveer in wijzersnaar	A3 646 14.0
	Tule voor schaalbevestiging	P5 420 03/08
	Torsieveer voor schakelunit	A3 651 16.0
	Kleine drukveer voor schakelaarsegment	A3 644 85.0
	Netschakelaar	A9 867 12.0
	Trekveer voor SKF2	A3 646 44.0
	Rimlockbushouder	B1 506 53.0
	Dipoolleiding	R 210 KN/03 AA
	Antenneschakelaar	A3 182 47.0
	 <u>DJ/RSw</u>	

BX 640 A

S1			S41		A3 152 99.0
S2			S42		A3 125 84.0
S3		A3 142 52.0	S44		A3 153 09.0
Z1			S45		
S4			C1	50 μ F)	
S5		A3 125 97.0	C1a	50 μ F)	A9 999 11/50+50
S6, 6a		A3 118 35.0	C2	50 μ F)	+50
S7, 7a		A3 118 36.0	C7	10 μ F	A9 999 04/10E
S8			C8	1500pF	A9 999 04/1K5
S9		A3 118 07.0	C9	18pF	49 005 59.4
S10			C10	18pF	49 005 59.4
S11			C11	30pF	28 212 36.4
S12		A3 126 85.0	C12	30pF	28 212 36.4
S13			C13	380pF	A9 999 04/330E+
S16					A9 999 04/47E
S17		A3 127 02.0	C14	270pF	A9 999 04/270E
S14			C15	12pF	A9 999 04/12E
S15		A3 127 03.0	C16	47pF	A9 999 04/47E
S20			C17	270pF	A9 999 05/270E
S21			C18	100pF	A9 999 04/100E
C31	15pF	A3 126 99.0	C19	18pF	A9 999 04/18E
S22			C20	33pF	A9 999 04/33E
S23		A3 125 98.0	C21	12pF	A9 999 04/12E
S24			C22	220pF	A9 999 04/220E
S25		A3 125 99.0	C23	10000pF	A9 999 04/10K
S26			C24	470pF	A9 999 04/470E
S27			C25	10000pF	A9 999 04/10K
C34	33pF	A3 127 00.0	C26	4700pF	A9 999 04/4K7
C35	33pF		C27	200pF	A9 999 04/200E
S28			C28	4700pF	A9 999 04/4K7
S29			C29	47pF	A9 999 04/47E
C36	110pF	A3 126 84.0	C30	4700pF	A9 999 04/4K7
C37	195pF		C32	30pF	28 212 36.4
S30			C33	18pF	49 005 59.4
S31		A3 127 00.0	C38	4700pF	A9 999 04/4K7
C42	33pF		C39	330pF	A9 999 04/330E
C43	33pF		C40	4700pF	A9 999 04/4K7
S32			C41	6800pF	A9 999 04/6K8
S33			C46	100pF	A9 999 04/100E
C44	110pF	A3 126 84.0	C47	47pF	A9 999 04/47E
C45	195pF		C48	4700pF	A9 999 04/4K7
S34			C49	10000pF	A9 999 04/10K
S36			C50	6800pF	A9 999 04/6K8
S36a		A3 127 01.0	C51	2200pF	A9 999 04/2K2
C53	47pF		C52	1000pF	A9 999 06/1K
C72	22pF		C54	4700pF	A9 999 04/4K7
S37			C55	4700pF	A9 999 04/4K7
S38			C56	10 μ F	AC 5705/10
S39			C57	10000pF	A9 999 04/10K
S40		A3 152 99.0	C58	8200pF	A9 999 06/8K2
			C61	4,7pF	A9 999 06/4E7
			C62	2200pF	A9 999 04/2K2
			C59	2700pF	A9 999 06/2K7
			C60	1000pF	A9 999 06/1K
			C63	22000pF	A9 999 06/22K

BX 640 A

C64	3300pF	A9 999 06/3K3	R24	1,6MΩ	}	A9 999 16/GL
C66	10000pF	A9 999 04/10K	R25	0,4MΩ		400K+1M6
C67	3000pF	A9 999 05/3K	R26	68000 Ω		A9 999 00/68K
C68	100pF	A9 999 04/100E	R27	68 Ω		A9 999 00/68E
C69	70pF	A9 999 07/20-	R28	10MΩ		A9 999 00/10M
		100E	R29	0,22MΩ		A9 999 00/220K
C70	100pF	A9 999 07/20-	R30	0,47MΩ		A9 999 00/470K
		100E	R31	4,7MΩ		A9 999 00/4M7
C73	680pF	A9 999 04/680E	R32	0,47MΩ		A9 999 00/470K
C74	47000pF	A9 999 06/47K	R33	0,22MΩ		A9 999 00/220K
C75	3,9pF	A9 999 04/3E9	R34	0,22MΩ		A9 999 00/220K
C80	2,2pF	A9 999 04/2E2	R35	0,56MΩ		A9 999 00/560K
C81	3900pF	A9 999 06/3K9	R36	0,1MΩ		A9 999 00/100K
C82	0,47μF	A9 999 06/470K	R37	1200 Ω		A9 999 00/1K2
C83	22000pF	A9 999 06/22K	R38	10 Ω		A9 999 00/10E
C84	1500pF	A9 999 06/1K5	R39	0,18MΩ		A9 999 00/180K
C85	1500pF	A9 999 06/1K5	R40	47000 Ω		A9 999 00/47K
R1	900 Ω	2xB1 636 10	R41	0,1MΩ		A9 999 00/100K
R1b	94 Ω	2xA9 999 00/47 E	R42	1MΩ	}	B1 639 19.0
R1a	100 Ω	B8 300 32B/100E	R42a	1MΩ		
R1c	18 Ω	48 494 10/18E	R43	10 Ω		A9 999 00/10E
R2	470 Ω	A9 999 00/470E	R44	2,7MΩ		A9 999 00/2M7
R3	33000 Ω	A9 999 00/33K	R45	8,2MΩ		A9 999 00/8M2
R4	0,22MΩ	A9 999 00/220K	R46	0,47MΩ		A9 999 00/470K
R5	1,2MΩ	A9 999 00/1M2	R47	0,39MΩ		A9 999 00/390K
R6	39000 Ω	A9 999 00/39K	R50	0,22MΩ		A9 999 00/220K
R7	150 Ω	A9 999 00/150E	R51	0,33MΩ		A9 999 00/330K
R8	47000 Ω	A9 999 00/47K	R52	1000 Ω		A9 999 00/1K
R9	33000 Ω	A9 999 00/33K	R53	1000 Ω		A9 999 00/1K
R10	4700 Ω	A9 999 00/4K7	R54	220 Ω		A9 999 00/220E
R11	10 Ω	A9 999 00/10E	R55	150 Ω		A9 999 00/150E
R12	10000 Ω	A9 999 00/10K	R56	820 Ω		A9 999 00/820E
R13	1000 Ω	A9 999 00/1K	R57	0,22MΩ		A9 999 00/220K
R14	2200 Ω	A9 999 00/2K2	R58	0,82MΩ		A9 999 00/820K
R15	82000 Ω	A9 999 00/82K	R59	47000 Ω		A9 999 00/47K
R17	0,33MΩ	A9 999 00/330K				
R18	1,2MΩ	A9 999 00/1M2				
R19	0,1MΩ	A9 999 00/100K				
R20	82000 Ω	A9 999 00/82K				
R21	2200 Ω	A9 999 00/2K2				
R22	47000 Ω	A9 999 00/47K				
R23	10000 Ω	A9 999 00/10K				

DJ/HL

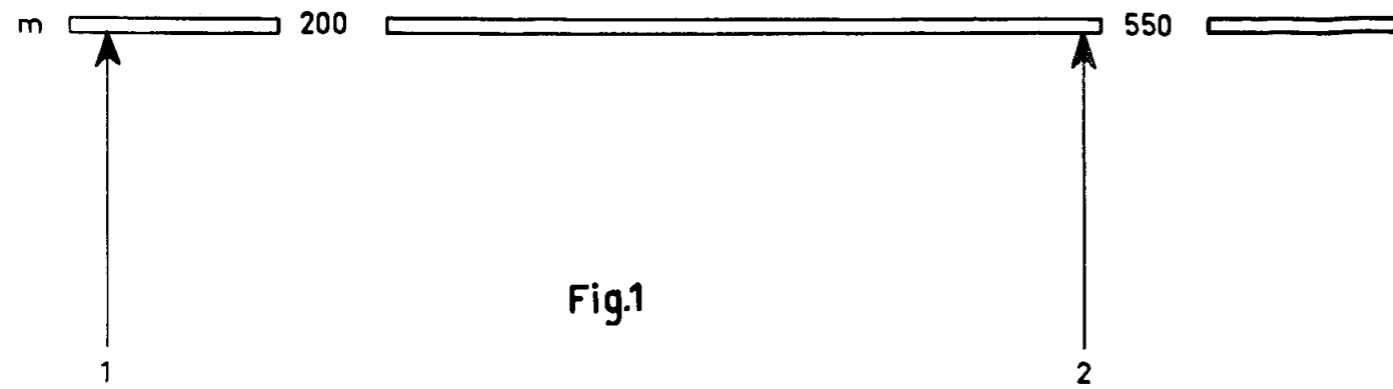

Fig.1

R 15421

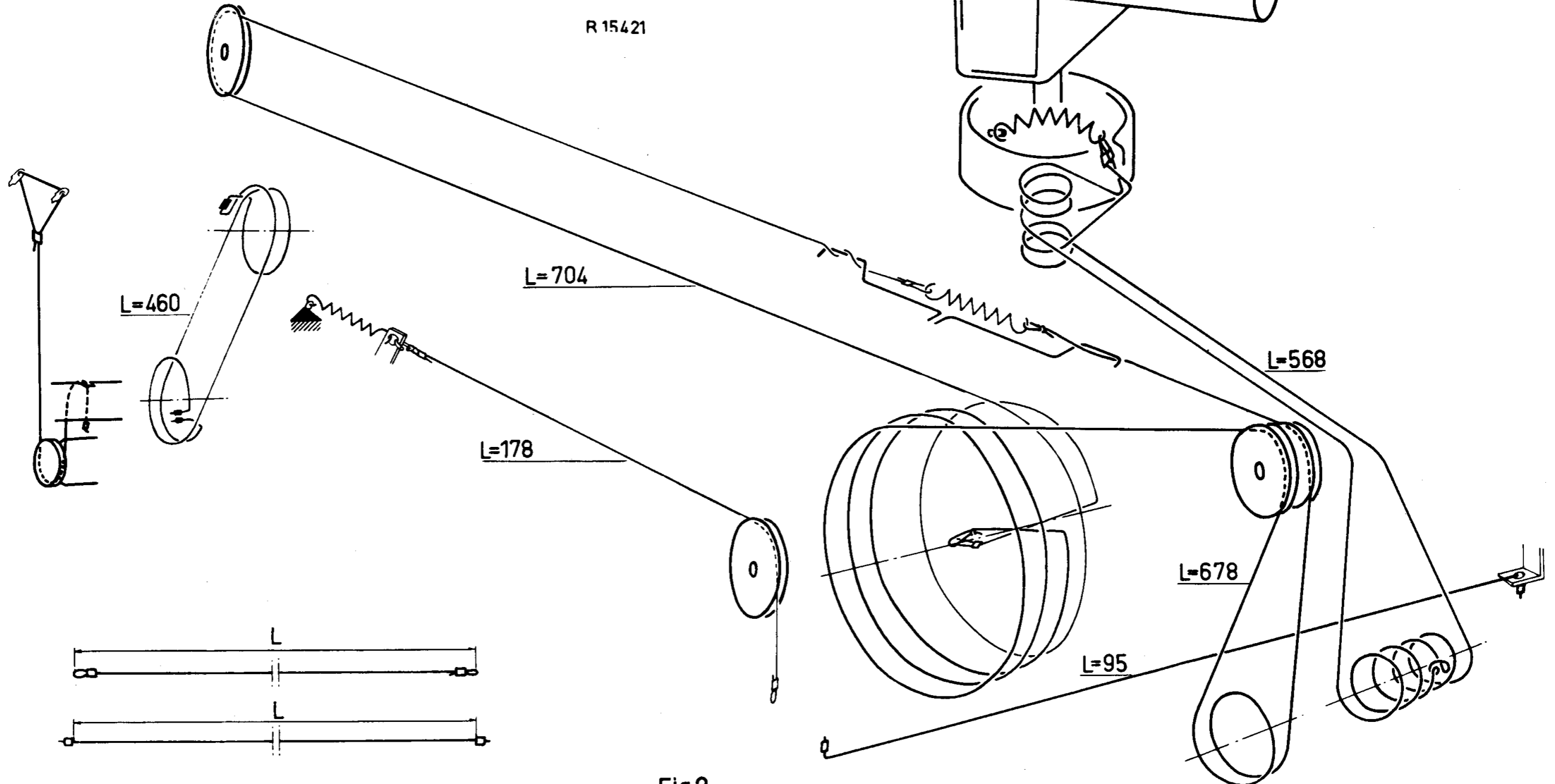
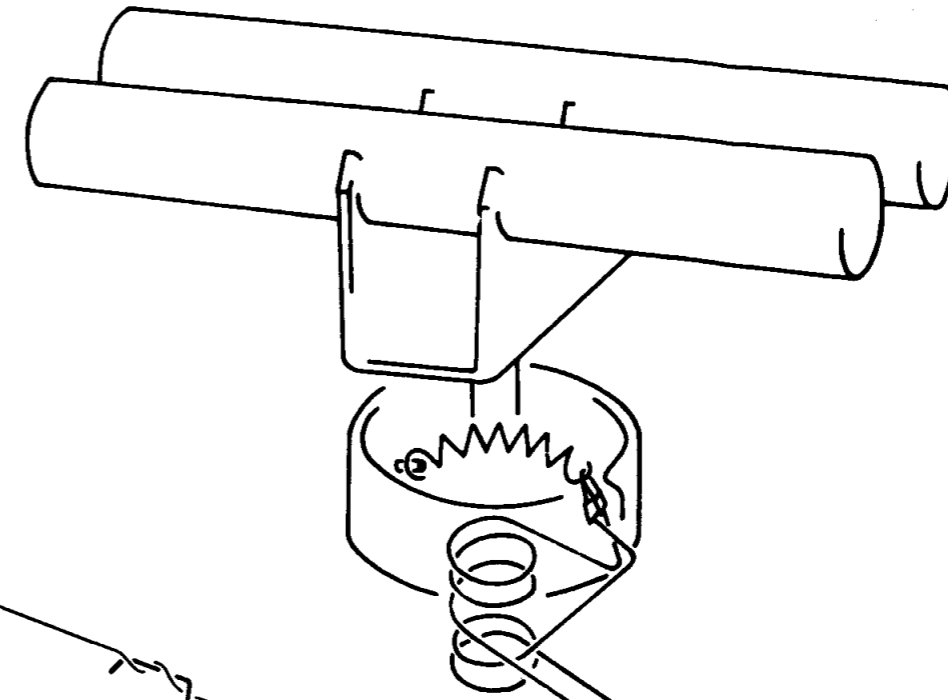
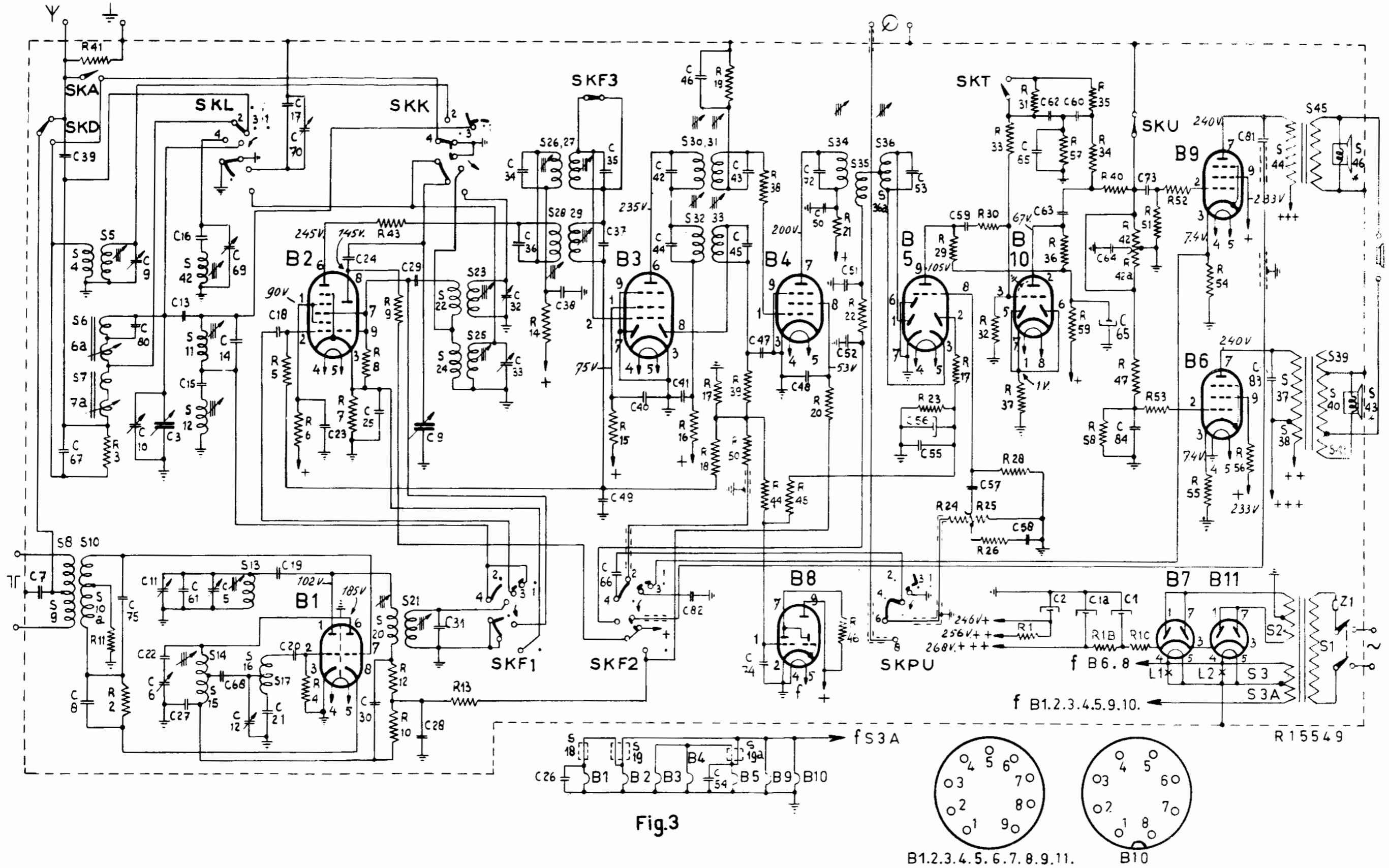

Fig.2

R 15460

BX 640A

S	8.9.10.10A.4.5.6.6A.7.7A.42.11.12.14.15.13.16.17.	20. 21. 22.23.24.25. 26. 27.28.29. 18.19.19A. 30.31. 32.33.	34.35.36.36A. 37.38.39.40.41.44.45.2.3.3A.1.46.43.
C	7. 39.67. 8.75.9.80.10.3.11.22.6.13.61.27.16.15.5.6.8.12.17.70.18.19.21.20.23.24.25.30.29.9.28.31.32.33.34.36.38.26.35.37. 66.40.42.44.41. 82.43.45.54.47.74.48.72.50.51.52. 53.55.56.59.57.58.85.62.63.60.2.64.1A.65.84.73. 81. 83.		
R	3.11.2.	5.6.4. 7.8. 43.9.12.10. 13.	14. 15. 16.17.18. 39.50.38.44.45.20.21.22.4.6. 43.29.17.24.25.30.32.33.37.26.28.1.31.57.36.35.34. 59.40.48.42.42. 47.51.52.53.54.56.



BX 640A

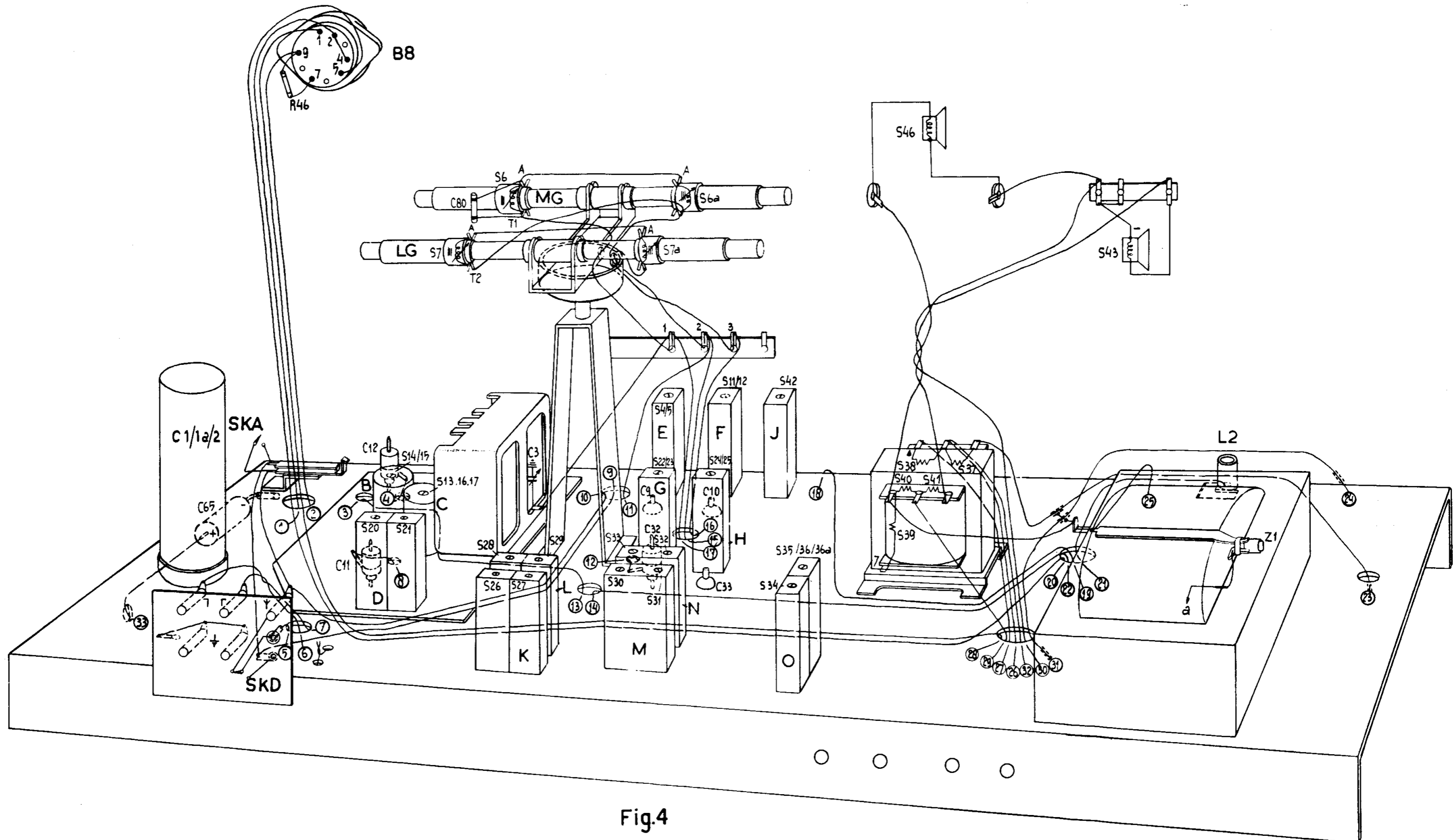

Fig.4

BX 640A

S	45	44	1	3a.3.2			19a	0	J	H	F	N	G	E	19	L	K	D. C.			B	18	A																																										
C	83	84		64	62	81	73	85	98	60	63	59	57	74	54	56	55	51	52	66	48	50	16	47	33	46	11	69	70	10	15	13	41	9	29	24	49	14	23	40	25	38	18	39	6	5	4	28	67	21	27	22	30	19	68	61	20	26	7	8	75	82	2	1a	1
R	56	55	78	47	53	31	42a	42	33	57	26	51	35	52	25	24	40	30	34	54	32	37	36	29	28	13	45	59	27	23	22	20	21	38	19	16	44	39	18	50	17	15	9	43	7	5	8	14	6	41	3	1a	1	10	12	4	2	11	10						

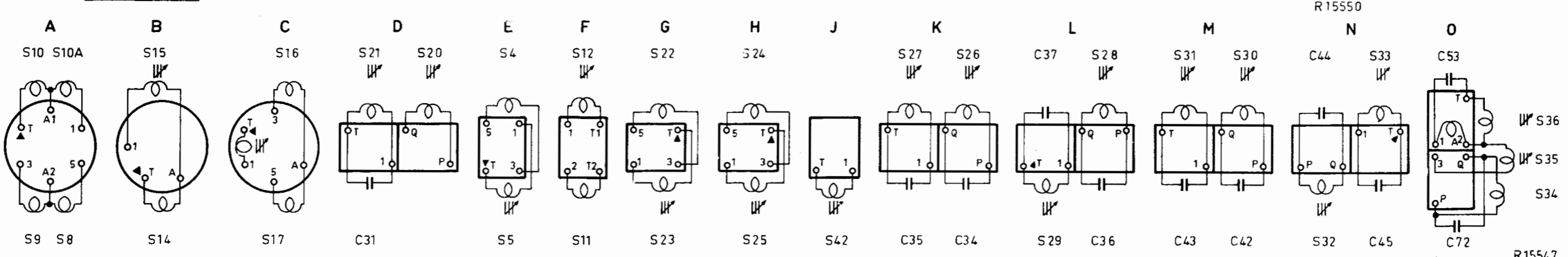
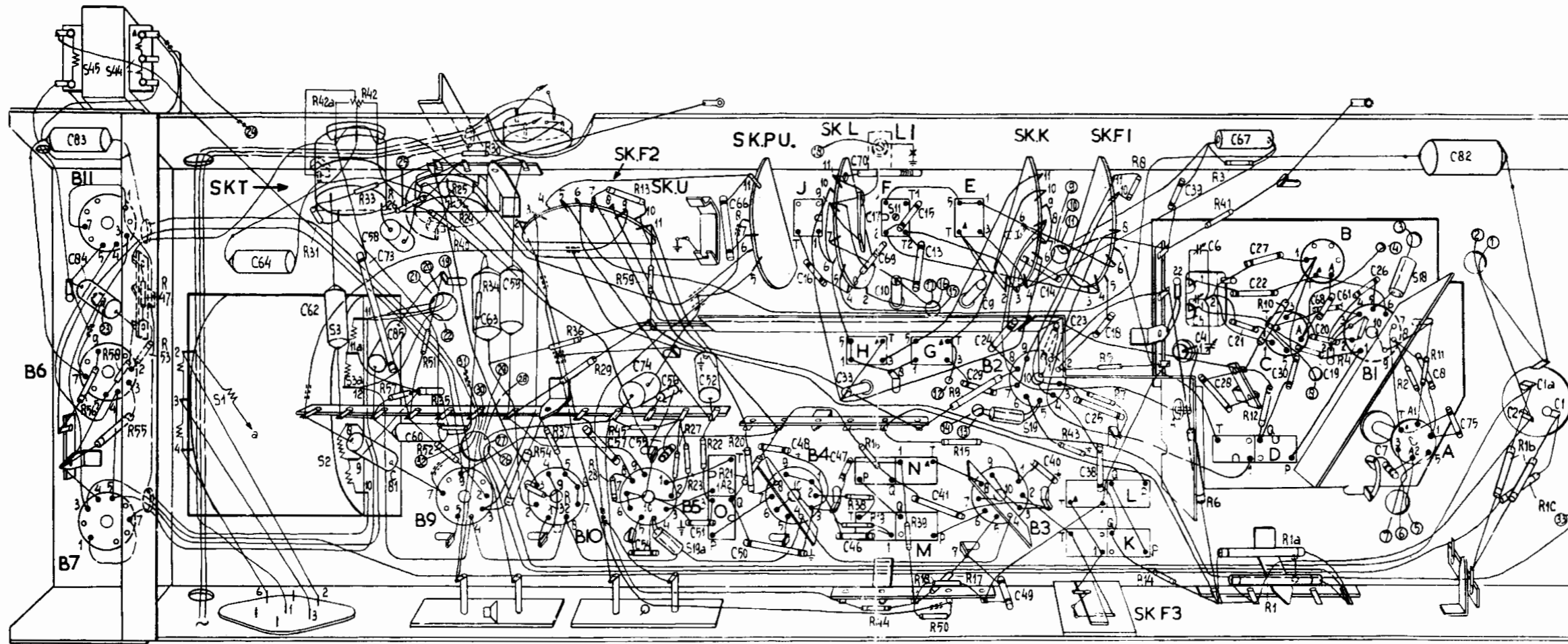

Fig.5